

THE EDGE™

Steel Framing

by
**Super
Stud**
Building Products, Inc.

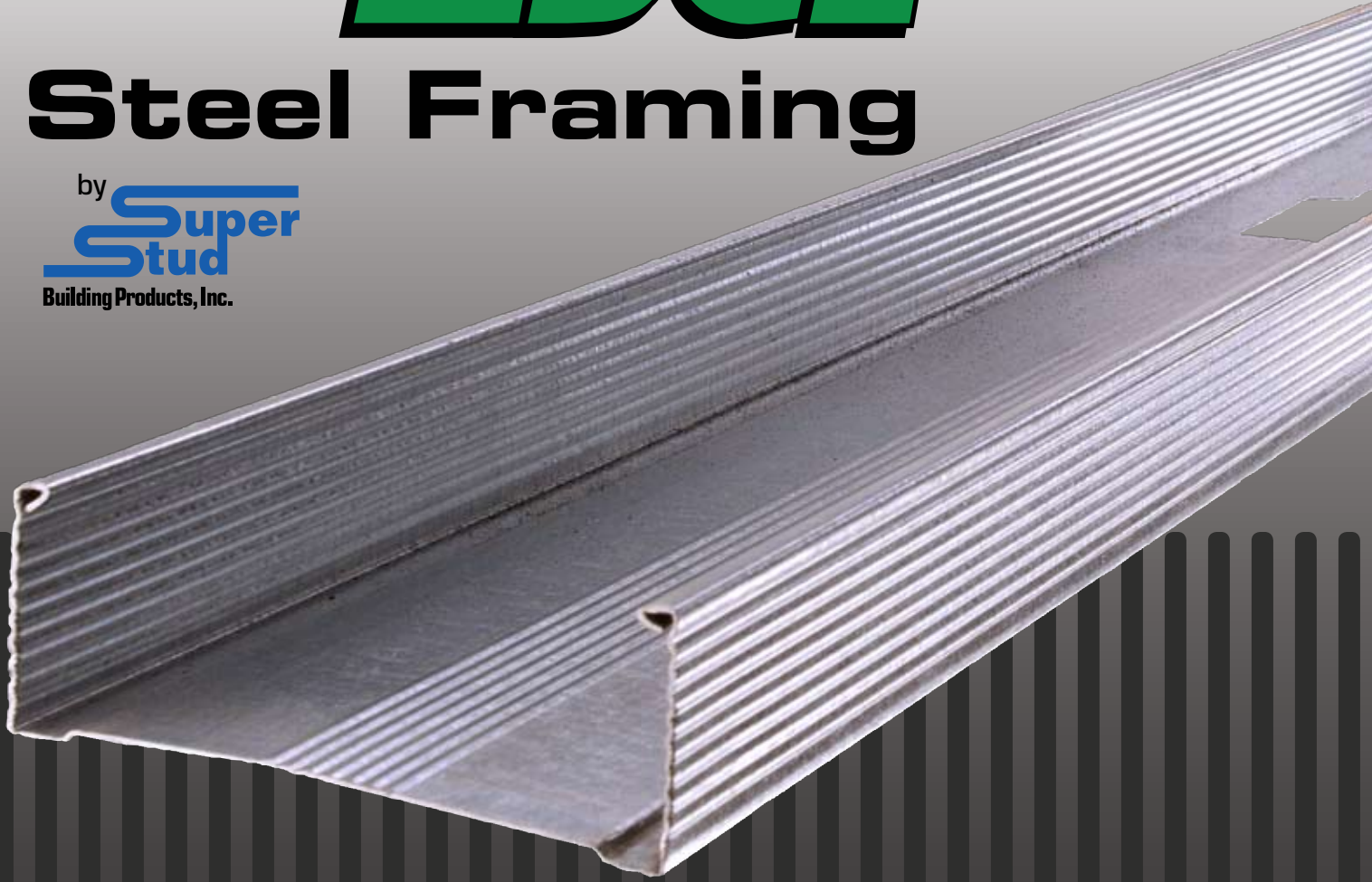

Safe. Stronger. More Secure.



www.edgesteel framing.com

The EDGE™ Steel Framing System is the safest EQ drywall stud on the market. Its patent pending design has no sharp edges anywhere along the length of the stud, meaning far fewer cuts and lacerations. Even our **EDGE™** track incorporates a hemmed lip for added safety.

The EDGE™ slides easily and smoothly along the track, making precise layout adjustments a snap!

The EDGE™ is offered in three thicknesses to accommodate any drywall framing need:

The EDGE™ 25 (EDS25) has a design thickness of 15 mils (0.015") and is an ideal replacement for conventional 25 gauge framing (0.0188").

The EDGE™ Performance 20 (EDS20P) drywall stud has a design thickness of 19 mils (0.019") and has been independently tested to comply with ASTM C645, as well as limiting heights as spelled out in ASTM C754 criteria for a conventional 20 gauge (0.0296" or 30 mils) drywall stud. **The EDGE™ Performance 20** is the perfect choice for maximum value in an ASTM compliant "EQ" framing solution when limiting heights are the primary design challenge. Should screw pullout values be a consideration it is suggested that the designer refer to **The EDGE™** screw pullout values on page 9.

The EDGE™ Super 20 (EDS20S) drywall stud utilizes a design thickness of 23 mils (0.023") and is recommended for applications where higher screw pullout resistance is needed, such as around doors or where cabinet backers might be employed. As with the entire **EDGE™** line, the **Super 20** complies with ASTM C645 and ASTM C754.

Strength by Design

Patent pending triangular lip provides greater flexural strength and stiffness. Result: greater wall heights, easier to screw into and a measurably safer product.

The EDGE™ is a truly unique design.

Manufactured using 40KSI material.

That, plus a measurably stiffer flange design combine to provide easier screw penetration.

Increased Productivity

Safer, stronger, fewer stripped screws.

Saves on Worker's Comp claims & downtime.

UL® Classified

Tested and approved for use in up to 4-hour rated wall assemblies.

Meets ASTM C645 & C754

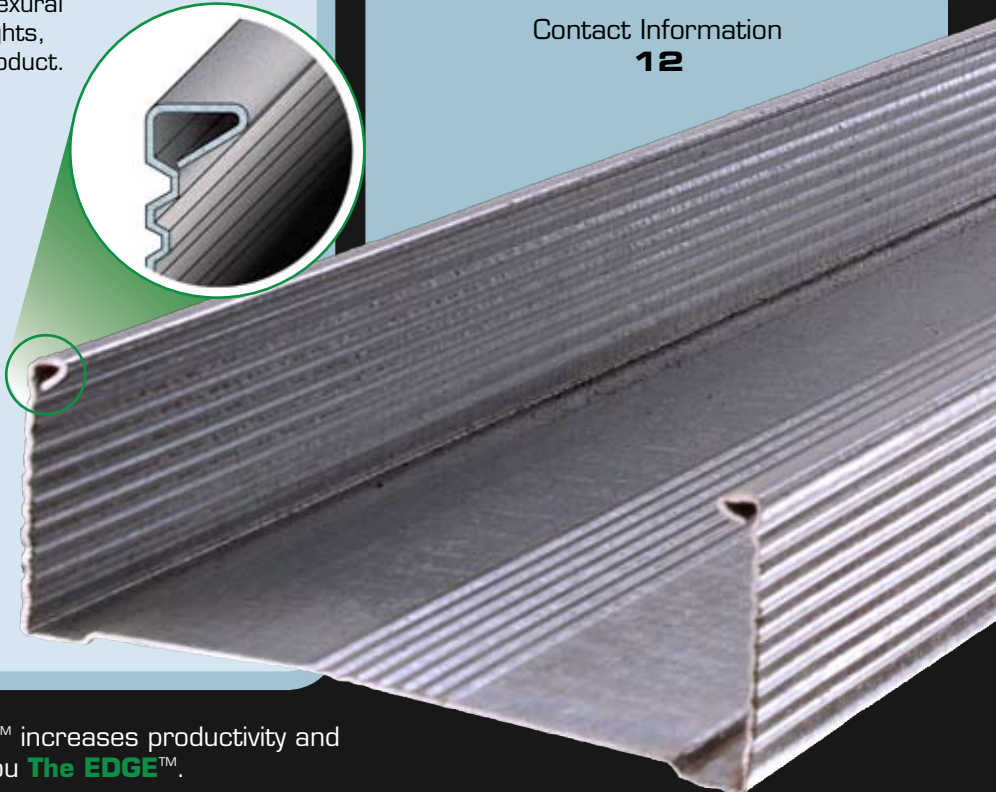
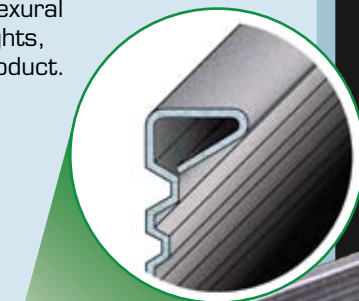

Table of Contents

Physical & Section Properties **3**

Limiting Heights Overview **4**

Composite Table **5**

Non-Composite Table – Fully Braced **6**

Non-Composite Table – Braced at 48" O.C. **7**

Interior Non-Bearing Wall Ratings **8**

Allowable Screw Design Values **9**

Deep Leg & Top Track Deflection **9**

Accessories **10**

LEED Information **11**

Contact Information **12**

PHYSICAL PROPERTIES

Stud						Track				
Model No.	Member Designation	Design Thickness (Mils)	Minimum Thickness (Inches)	Yield	Coating	Model No.	Design Thickness (Mils)	Minimum Thickness (Inches)	Yield	Coating
The EDGE™ 25	EDS25	15	0.0145	40 KSI	G40 _{2,3}	TRACK	15	0.0145	40 KSI	G40 _{2,3}
The EDGE™ Performance 20	EDS20P	19	0.0179	40 KSI	G40 _{2,3}	TRACK	19	0.0179	40 KSI	G40 _{2,3}
The EDGE™ Super 20	EDS20S	23	0.022	40 KSI	G40 _{2,3}	TRACK	23	0.022	40 KSI	G40 _{2,3}
DW 30 ₁		31	0.0296	33 KSI	G40 _{2,3}	TRACK	31	0.0296	33 KSI	G40 _{2,3}
DW 33 ₁		35	0.0329	33 KSI	G40 _{2,3}	TRACK	35	0.0329	33 KSI	G40 _{2,3}
Stud web sizes: 1-5/8", 2-1/2", 3-5/8", 4", 6"				Flange: 1-1/4"		Track web sizes: 1-5/8", 2-1/2", 3-5/8", 4", 6"				
Knockout sizes: 1-5/8" stud = 3/4" x 1-1/2" 2-1/2", 3-5/8", 4", 6" = 1-1/2" x 2-1/2"				Return lip: 0.350"		Flange: 1-1/4"				

- Notes:
- 1 - DW 30 and DW 33 are special order products and are traditional C-shaped studs
 - 2 - Or equivalent per ASTM C645
 - 3 - G60 and G90 are available by special order.
 - 4 - Mils are rounded to the nearest thousandth.

SECTION PROPERTIES - THE EDGE™ STUD

Section	Design Thickness (Mils)	Gross Section Properties						Effective Section Properties			Torsional Properties				
		Area	Weight	I _x	r _x	I _y	r _y	I _{xe}	S _{xe}	Ma	X _o	J _x 10 ⁻⁵	C _w	R _o	Beta
		(in ²)	lbs/ft	(in ⁴)	(in)	(in ⁴)	(in)	(in ⁴)	(in ³)	in-lbs	(in)	(in ⁴)	(in ⁶)	(in)	
1-5/8"	15	0.0682	0.240	0.0324	0.690	0.0142	0.4560	0.0284	0.0285	683	-1.050	0.512	0.0082	1.33	0.377
	19	0.0846	0.249	0.0398	0.069	0.0173	0.4532	0.0369	0.0346	930	-1.035	0.997	0.0097	1.32	0.385
	23	0.1003	0.364	0.0480	0.682	0.0208	0.4496	0.0467	0.0516	1236	-1.024	0.185	0.0114	1.31	0.389
2-1/2"	15	0.0813	0.285	0.0851	1.023	0.0162	0.4470	0.0730	0.0483	1156	-0.910	0.610	0.0203	1.44	0.601
	19	0.1011	0.350	0.1049	1.019	0.0198	0.4434	0.0950	0.0654	1567	-0.901	1.191	0.0244	1.43	0.603
	23	0.1236	0.434	0.1271	1.014	0.0239	0.4396	0.1203	0.0867	2076	-0.891	2.218	0.0289	1.41	0.601
3-5/8"	15 ₁	0.0982	0.344	0.1992	1.424	0.0180	0.4280	0.1717	0.0758	1815	-0.789	0.736	0.0460	1.68	0.779
	19	0.1222	0.422	0.2463	1.419	0.0220	0.4251	0.2250	0.1042	2497	-0.780	1.440	0.0557	1.67	0.782
	23	0.1497	0.523	0.2994	1.414	0.0266	0.4210	0.2867	0.1397	3347	-0.770	2.686	0.0662	1.66	0.785
4"	15 ₂	0.1038	0.363	0.2505	1.553	0.0185	0.4220	0.2144	0.0847	2028	-0.756	0.779	0.0572	1.77	0.818
	19 ₁	0.1293	0.446	0.3100	1.548	0.0226	0.4187	0.2818	0.1167	2795	-0.748	1.523	0.0695	1.76	0.819
	23	0.1584	0.553	0.3770	1.543	0.0272	0.4147	0.3600	0.1567	3754	-0.738	2.842	0.0827	1.76	0.824
6"	15 ₂	0.1338	0.467	0.6571	2.216	0.0203	0.3900	0.5416	0.1365	3270	-0.623	1.004	0.1429	2.33	0.929
	19 ₂	0.1669	0.560	0.8153	2.210	0.0249	0.3864	0.7187	0.1892	4531	-0.616	1.966	0.1741	2.32	0.930
	23 ₂	0.0248	0.711	0.9943	2.203	0.0300	0.3824	0.9265	0.2557	6124	-0.608	3.674	0.2079	2.32	0.931

- Notes:
- Section properties were determined in accordance with AISI North American Specification for the Design of Cold-Formed Steel Members, 2007 edition.
 - Calculated effective moment of inertia [I_{xe}] is based on serviceability determination
 - Effective properties and moment capacity did not incorporate stress increase as a result of cold work of forming.
 - Allowable bending moment is based on a fully braced section about its major axis.

- 1 - Web-depth to thickness ratio exceeds 200. Web stiffeners are required at all bearing locations, and no web holes are permitted in non-composite conditions.
- 2 - Web-depth to thickness ratio exceeds 260. Web stiffeners are required at all bearing and intermediate locations, and no web holes are permitted in non-composite conditions

Limiting Wall Heights Explained

The **EDGE™** EQ Steel Drywall Framing System has multiple applications, most notably for use in walls, ceilings and soffits. The majority of assemblies can be designed based upon the tables within this brochure; however, some projects will require the assistance of a professional. Use the images on this page to find the required assembly and follow the instructions to choose the appropriate **EDGE™** assembly.

NOTE: Technical services available through Super Stud 800-477-7883.

Composite Wall Assemblies

Composite walls are assemblies where drywall sheathing is attached to both stud flanges at the full height of the wall as depicted at right. The **EDGE™** has been tested in accordance with the 2009 IBC and conforms to AC86-2010. Values shown in the table on **page 5** were obtained using 1/2" generic gypsum board. Using 5/8" board would yield greater values. Complete limiting height tables are also available at www.edgesteelframing.com.

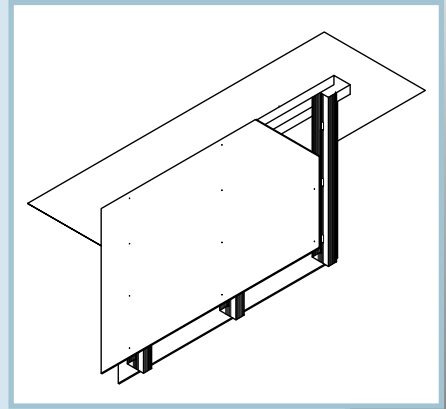

Non-Composite Wall Assemblies

Non-composite wall assemblies do not have the drywall sheathing attached to the full height of the wall, such as when studs continue above a grid ceiling. These wall assemblies are common in many structures. Limiting height data for non-composite assemblies can be found on **pages 6 and 7** or at www.edgesteelframing.com. While these tables cover most conditions, there may be situations or conditions where a professional should be consulted.

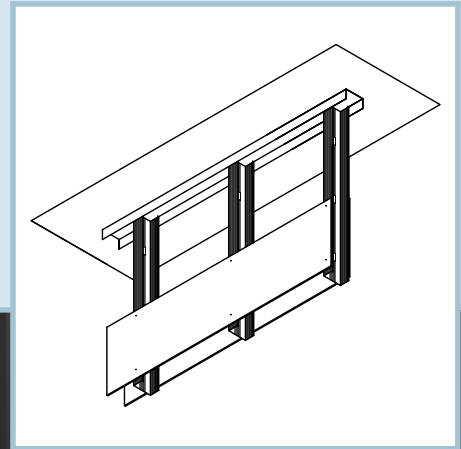
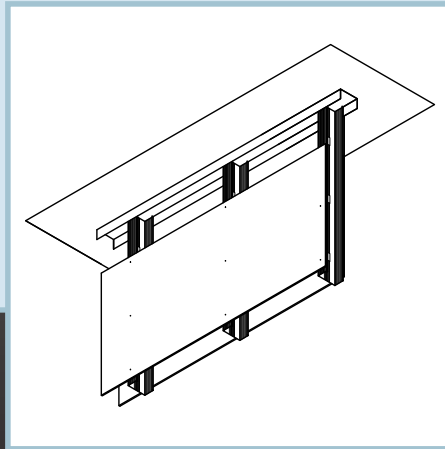
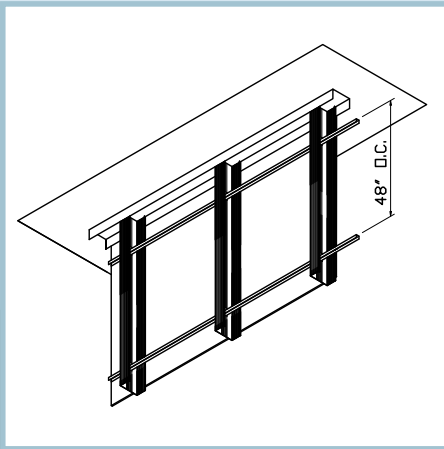

Alternative Framing Conditions and Applications

The **EDGE™** can also be utilized in framing conditions other than standard wall assemblies, such as ceiling runners, soffits, and chase or furred walls. Special attention should be paid to unusual ceiling loads or to whether these non-standard walls are composite or non-composite assemblies. Call us at **800-477-7883** for information and assistance with these design conditions.

Note to the Design Professional: Our Composite Tables were tested to AC86-10. In addition, we have added the L/480 column for your review to illustrate the increased stiffness your wall will achieve using **The EDGE™**.

ALLOWABLE COMPOSITE LIMITING HEIGHTS: AC86-10																				
THE EDGE™ EQ-STUD-COMPOSITE LIMITING HEIGHTS - 1/2" GYPSUM WALLBOARD (FT. - IN.)																				
Depth	EQ Gauge	Design Thickness (Mils)	Member Designation	Spacing (in.)	5 (psf)				7.5 (psf)				10 (psf)				15 (psf)			
					L/120	L/240	L/360	L/480	L/120	L/240	L/360	L/480	L/120	L/240	L/360	L/480	L/120	L/240	L/360	L/480
					ft-in	ft-in	ft-in	ft-in	ft-in	ft-in	ft-in	ft-in	ft-in	ft-in	ft-in	ft-in	ft-in	ft-in	ft-in	ft-in
1-5/8"	25 EQ	15	158EDS25	12	13-4 f	11-1	9-9	8-10	10-11 f	9-8	8-6	7-9	9-5 f	8-10	7-9					
				16	11-7 f	10-1	8-10	8-0	9-5 f	8-10	7-9		8-2 f	8-0						
				24	9-5 f	8-10	7-9													
	20P* EQ	19	158EDS20P	12	14-4	11-11	10-5	9-5	12-6	10-5	9-1	8-2	11-2 f	9-5	8-2					
				16	13-0	10-9	9-5	8-6	11-2 f	9-5	8-2		9-8 f	8-6						
				24	11-2 f	9-5	8-2		9-1 f	8-2			7-10 f							
	20S* EQ	23	158EDS20S	12	14-11	12-4	10-10	9-11	13-1	10-9	9-5	8-7	11-10	9-9	8-6	7-9	8-6 f			
				16	13-7	11-2	9-10	8-11	11-10	9-9	8-6	7-9	10-9	8-10	7-9					
				24	11-10	9-9	8-6	7-9	10-4	8-6			9-2 f							
2-1/2"	25 EQ	15	250EDS25	12	16-5 f	14-1	12-4	11-1	13-5 f	12-4	10-8	9-7	11-7 f	11-2	9-7	8-8				
				16	14-2 f	12-10	11-2	10-0	11-7 f	11-2	9-7	8-8	10-0 f	10-0	8-8	7-9				
				24	11-7 f	11-2	9-7	8-8	9-5 f	9-5 f	8-3		8-2 f	8-2 f						
	20P* EQ	19	250EDS20P	12	18-3	15-1	13-4	12-2	15-10 f	13-2	11-7	10-5	13-8 f	12-0	10-5	9-4	9-0 f	9-0 f	8-11	8-1
				16	16-7	13-8	12-1	10-11	13-8 f	12-0	10-5	9-4	11-10 f	10-9	9-4	8-5	7-10 f	7-10 f	7-10 f	
				24	13-8 f	12-0	10-5	9-4	11-2 f	10-3	8-11	8-1	9-8 f	9-2	8-1					
	20S* EQ	23	250EDS20S	12	18-5	15-2	13-4	12-1	16-1	13-3	11-7	10-6	14-7	12-0	10-6	9-6	10-7 f	10-5	9-1	8-3
				16	16-9	13-9	12-1	10-11	14-7	12-0	10-6	9-6	13-3	10-10	9-6	8-7	9-2 f	9-2 f	8-3	
				24	14-7	12-0	10-6	9-6	12-9	10-5	9-1	8-3	11-4 f	9-5	8-3					
3-5/8"	25 EQ	15	358EDS25	12	18-8 f	17-10	15-8	14-4	15-3 f	15-3 f	13-8	12-6	13-2 f	13-2 f	12-5	11-3	8-8 f	8-8 f	8-8 f	8-8 f
				16	16-2 f	16-2 f	14-3	13-0	13-2 f	13-2 f	12-5	11-3	11-5 f	11-5 f	11-1	9-11				
				24	13-2 f	13-2 f	12-5	11-3	10-9 f	10-9 f	10-6	9-5	9-4 f	9-4 f	9-3	8-4				
	20P* EQ	19	358EDS20P	12	22-7 f	19-3	17-0	15-5	18-6 f	16-10	14-10	13-6	16-0 f	15-4	13-6	12-3	10-6 f	10-6 f	10-6 f	10-4
				16	19-7 f	17-6	15-5	14-0	16-0 f	15-4	13-6	12-3	13-10 f	13-10 f	12-3	10-11	9-0s	9-0s	9-0s	9-0s
				24	16-0 f	15-5	13-6	12-3	13-1 f	13-1 f	11-9	10-4	11-4 f	11-4 f	10-4	9-2				
	20S* EQ	23	358EDS20S	12	23-5	19-4	17-2	15-8	20-6	16-11	15-0	13-8	18-3 f	15-4	13-7	12-5	12-0 f	12-0 f	11-11	10-7
				16	21-3	17-7	15-7	14-3	18-3 f	15-4	13-7	12-5	15-10 f	13-11	12-4	11-2	10-5 f	10-5 f	10-5 f	9-5
				24	18-3 f	15-4	13-7	12-5	14-11 f	13-5	11-11	10-7	12-11 f	12-2	10-6	9-5	8-6 f	8-6 f	8-6 f	7-11
4"	25 EQ	15	400EDS25	12	21-4 f	19-4	17-0	15-11	17-5 f	17-0	14-11	13-11	15-1 f	15-1 f	13-7	12-8				
				16	18-6 f	17-8	15-7	14-6	15-1 f	15-1 f	13-7	12-8	13-1 f	13-1 f	12-4					
				24	15-1 f	15-1 f	13-7	12-8	12-4 f	12-4 f	11-10	11-1								
	20P* EQ	19	400EDS20P	12	25-3 f	21-2	18-7	17-3	20-8 f	18-7	16-4	15-2	17-10 f	17-0	14-10	13-9	11-9 f	11-9 f	11-9 f	11-9 f
				16	21-11 f	19-4	17-0	15-9	17-10 f	17-0	14-10	13-9	15-6 f	15-6 f	13-6	12-6				
				24	17-10 f	17-0	14-10	13-9	14-7 f	14-7 f	13-0	12-0	12-8 f	12-8 f	11-10					
	20S* EQ	23	400EDS20S	12	26-7	21-4	18-9	17-3	23-5	18-9	16-5	15-1	20-10 f	17-1	14-11	13-9	13-9 f	13-9 f	13-1	12-0
				16	24-3	19-5	17-1	15-8	20-10 f	17-1	14-11	13-9	18-1 f	15-6	13-7	12-5	11-11 f	11-11 f	11-10	
				24	20-10 f	17-1	14-11	13-9	17-0 f	14-11	13-1	12-0	14-9 f	13-7	11-10					
6"	25 EQ	15	600EDS25	12	25-6 f	25-6	22-4	20-5	20-10 f	20-10 f	19-6	17-10	18-0 f	18-0 f	17-9	16-2				
				16	22-1 f	22-1 f	20-4	18-6	18-0 f	18-0 f	17-9	16-2	15-7 f	15-7 f	15-7 f	14-8				
				24	18-0 f	18-0 f	17-9	16-2	14-5 f	14-5 f	14-5 f	14-1								
	20P* EQ	19	600EDS20P	12	30-0 f	26-11	23-6	21-8	24-6 f	23-6	20-7	18-11	21-3 f	21-3 f	18-8	17-3	14-0 f	14-0 f	14-0 f	14-0 f
				16	26-0 f	24-6	21-5	19-9	21-3 f	21-3 f	18-8	17-3	18-5 f	18-5 f	17-0	15-8	11-9s	11-9s	11-9s	11-9s
				24	21-3 f	21-3 f	18-8	17-3	17-4 f	17-4 f	16-4	15-0	15-0 f	15-0 f	14-9	13-7				
	20S* EQ	23	600EDS20S	12	31-2 f	27-9	24-4	22-6	25-6 f	24-2	21-3	19-8	22-1 f	22-0	19-4	17-10	14-2 f	14-2 f	14-2 f	14-2 f
				16	27-0 f	25-2	22-1	20-5	22-1 f	22-0	19-4	17-10	19-1 f	19-1 f	17-7	16-2	12-3 f	12-3 f	12-3 f	12-3 f
				24	22-1 f	22-0	19-4	17-10	18-0 f	18-0 f	16-11	15-7	15-7 f	15-4	14-1					

NOTE: Composite Limiting Heights for L/480 deflection criteria are presented for comparison only and to illustrate the exceptional flexural stiffness of **The EDGE™** design. Calculations based on L/360 values

Allowable composite limiting heights are calculated using ICC-ES AC86-2010.

Minimum safety factor for strength = 1.508 for 5 to 10 psf, and 2.327 for 15 psf.

The gypsum board must be applied full height to each stud flange and installed using minimum No. 6 type S drywall screws spaced a maximum of 12-inches on-center to the framing members in accordance with ASTM C754-2009 and IBC 2009.

No fasteners are required for attaching the stud to the track.

The stud end bearing must be a minimum of 1 inch.

Minimum material yield strength equals 40KSI.

'f' adjacent to the height value indicates that flexural stress controls the allowable wall height.

's' adjacent to the height value indicates that shear/end reaction controls the allowable wall height.

No "f" or "s" adjacent to the height value indicates deflection controls the allowable wall height.

* **The EDGE™** Performance 20 and **The EDGE™** Super 20



ALLOWABLE NON-COMPOSITE LIMITING HEIGHTS

FULLY BRACED

THE EDGE™ EQ-STUD NON-COMPOSITE LIMITING HEIGHTS

Depth	EQ Gauge	Design Thickness (Mils)	Member Designation	Spacing (in.)	5 (psf)			7.5 (psf)			10 (psf)			15 (psf)		
					L/120	L/240	L/360	L/120	L/240	L/360	L/120	L/240	L/360	L/120	L/240	L/360
					ft - in	ft - in	ft - in	ft - in	ft - in	ft - in	ft - in	ft - in	ft - in	ft - in	ft - in	ft - in
1-5/8"	25 EQ	15	158EDS25	12	9-1	7-3	6-4	8-0	6-4	5-6	7-3	5-9	5-0	6-2f	5-0	4-5
				16	8-3	6-7	5-9	7-3	5-9	5-0	6-5f	5-3	4-7	5-3f	4-7	4-0
				24	7-3	5-9	5-0	6-2f	5-0	4-5	5-3f	4-7	4-0	4-4c	4-0	3-6
	20P* EQ	19	158EDS20P	12	9-11	7-11	6-11	8-8	6-11	6-0	7-11	6-3	5-6	6-11	5-6	4-9
				16	9-0	7-2	6-3	7-11	6-3	5-6	7-2	5-8	5-0	6-1c	5-0	4-4
				24	7-11	6-3	5-6	6-11	5-6	4-9	6-1c	5-0	4-4	5-0c	4-4	3-10
	20S* EQ	23	158EDS20S	12	10-6	8-6	7-5	9-5	7-5	6-6	8-6	6-9	5-11	7-5f	5-11	5-6
				16	9-9	7-9	6-9	8-6	6-9	5-11	7-10	6-2	5-5	6-9f	5-5	4-8
				24	8-6	6-9	5-11	7-5	5-11	5-2	6-9	5-5	4-8	5-9f	4-8	4-1
2-1/2"	25 EQ	15	250EDS25	12	12-8	10-0	8-9	11-0	8-9	7-8	9-8f	8-0	7-0	7-10f	7-0	6-1
				16	11-6	9-1	8-0	9-8f	8-0	7-0	8-4f	7-3	6-4	5-11c	5-11c	5-6
				24	9-8f	8-0	7-0	7-10f	7-0	6-1	5-11c	5-11c	5-6	4-0c	4-0c	4-0c
	20P* EQ	19	250EDS20P	12	13-9	10-11	9-7	12-0	9-7	8-4	10-11	8-8	7-7	9-2f	7-7	6-8
				16	12-6	9-11	8-8	10-11	8-8	7-7	9-8f	7-11	6-11	7-11f	6-11	6-0
				24	10-11	8-8	7-7	9-2	7-7	6-8	7-11f	6-11	6-0	6-0c	6-0	5-3
	20S* EQ	23	250EDS20S	12	14-10	11-10	10-4	13-0	10-4	9-0	11-10	9-4	8-2	10-4	8-2	7-2
				16	13-6	10-9	9-4	11-10	9-4	8-2	10-9	8-6	7-5	9-1f	7-5	6-6
				24	11-10	9-4	8-2	10-4	8-2	7-2	9-1f	7-5	6-6	7-5f	6-6	5-8
3-5/8"	25 EQ	15	358EDS25	12	16-8	13-3	11-7	13-10f	11-7	10-1	10-11c	10-6	9-2	7-4c	7-4c	7-4c
				16	14-9f	12-0	10-6	10-11c	10-6	9-2	8-2c	8-2c	8-2c	5-6c	5-6c	5-6c
				24	10-11c	10-6	9-2	7-4c	7-4c	7-4c	5-6c	5-6c	5-6c	3-8c	3-8c	3-8c
	20P* EQ	19	358EDS20P	12	18-3	14-6	12-8	15-11	12-8	11-1	14-1f	11-6	10-1	11-3c	10-1	8-9
				16	16-7	13-2	11-6	14-1f	11-6	10-1	12-2f	10-5	9-2	8-5c	8-5c	8-0
				24	14-1f	11-6	10-1	11-3c	10-1	8-9	8-5c	8-5c	8-0	5-8c	5-8c	5-8c
	20S* EQ	23	358EDS20S	12	19-9	15-8	13-9	17-3	13-9	12-0	15-8	12-6	10-11	13-4f	10-11	9-6
				16	18-0	14-3	12-6	15-8	12-6	10-11	14-2f	11-4	9-11	11-7f	9-11	8-8
				24	15-8	12-6	10-11	13-4f	10-11	9-6	12-6	9-11	8-8	8-5c	8-5c	7-7
4"	25 EQ	15	400EDS25	12	17-11	14-3	12-5	14-3c	12-5	10-11	10-8c	10-8c	9-11	7-2c	7-2c	7-2c
				16	15-7f	12-11	11-4	10-8c	10-8c	9-11	8-0c	8-0c	8-0c	5-4c	5-4c	5-4c
				24	10-8c	10-8c	9-11	7-2c	7-2c	7-2c	5-4c	5-4c	5-4c	3-7c	3-7c	3-7c
	20P* EQ	19	400EDS20P	12	19-8	15-7	13-8	17-2	13-8	11-11	14-11f	12-5	10-10	11-0c	10-10	9-6
				16	17-10	14-2	12-5	14-11f	12-5	10-10	12-5c	11-3	9-10	8-3c	8-3c	8-3c
				24	14-11f	12-5	10-10	11-0c	10-10	9-6	8-3c	8-3c	8-3c	5-6c	5-6c	5-6c
	20S* EQ	23	400EDS20S	12	21-4	16-11	14-10	18-8	14-10	12-11	16-11	13-5	11-9	14-1f	11-9	10-3
				16	19-5	15-5	13-5	16-11	13-5	11-9	15-0f	12-3	10-8	12-3f	10-8	9-4
				24	16-11	13-5	11-9	14-1f	11-9	10-3	12-3	10-8	9-4	8-3c	8-3c	8-2
6"	25 EQ	15	600EDS25	12	18-10c	18-10c	16-9	12-7c	12-7c	12-7c	9-5c	9-5c	9-5c	6-4c	6-4c	6-4c
				16	14-2c	14-2c	14-2c	9-5c	9-5c	9-5c	7-1c	7-1c	7-1c	4-9c	4-9c	4-9c
				24	9-5c	9-5c	9-5c	6-4c	6-4c	6-4c	4-9c	4-9c	4-9c	3-2c	3-2c	3-2c
	20P* EQ	19	600EDS20P	12	26-7	21-2	18-6	19-11c	18-6	16-2	14-11c	14-11c	14-8	9-11c	9-11c	9-11c
				16	22-5c	19-2	16-9	14-11c	14-11c	14-8	11-2c	11-2c	11-2c	7-6c	7-6c	7-6c
				24	14-11c	16-9	14-8	9-11c	9-11c	9-11c	7-6c	7-6c	7-6c	5-0c	5-0c	5-0c
	20S* EQ	23	600EDS20S	12	29-0	23-0	20-1	25-4	20-1	17-7	22-0f	18-3	16-0	16-10c	16-0	13-11
				16	26-4	20-11	18-3	22-0f	18-3	16-0	18-11c	16-7	14-6	12-8c	12-8c	12-8c
				24	22-0f	18-3	16-0	16-10c	16-0	13-11	12-7c	12-7c	12-7c	8-5c	8-5c	8-5c

NOTE:

Heights are based on the AISI North American Specification for the Design of Cold-Formed Steel Members, 2007 edition

Heights are limited by moment, deflection, shear and web crippling (assuming 1" end bearing)

Minimum material yield strength equals 40KSI for 15-, 19- and 23-mils studs

"f" denotes moment capacity controlled the limiting height

"c" denotes that web crippling controlled the limiting heights

No "f" or "c" adjacent to the height value indicates deflection controls the allowable wall height.

If a bearing stiffener is used a higher limiting height is possible

* The EDGE™ Performance 20 and The EDGE™ Super 20



ALLOWABLE NON-COMPOSITE LIMITING HEIGHTS

**BRACED AT 48"
O.C.**

THE EDGE™ EQ-STUD NON-COMPOSITE LIMITING HEIGHTS

Section	EQ Gauge	Design Thickness (Mils)	Member Designation	Spacing (in.)	5 (psf)			7.5 (psf)			10 (psf)			15 (psf)		
					L/120	L/240	L/360	L/120	L/240	L/360	L/120	L/240	L/360	L/120	L/240	L/360
					ft-in	ft-in	ft-in	ft-in	ft-in	ft-in	ft-in	ft-in	ft-in	ft-in	ft-in	ft-in
1-5/8"	25 EQ	15	158EDS25	12	9-1 f	7-4	6-5	7-5 f	6-5	5-7	6-5 f	5-10	5-1	5-3 f	5-1	4-5
				16	7-11 f	6-8	5-10	6-5 f	5-10	5-1	5-7 f	5-4	4-8	4-7 f	4-8	4-1
				24	6-5 f	5-10	5-1	5-3 f	5-1	4-5	4-7 f	4-7 f	4-1	3-9 f	3-9 f	3-7
	20P* EQ	19	158EDS20P	12	10-1	8-0	7-0	8-7 f	7-0	6-1	7-6 f	6-4	5-7	6-1 f	5-7	4-10
				16	9-2 f	7-3	6-4	7-6 f	6-4	5-7	6-6 f	5-9	5-1	5-3 f	5-1	4-5
				24	7-6 f	6-4	5-7	6-1 f	5-7	4-10	5-3 f	5-1	4-5	4-4 f	4-5	3-10
	20S* EQ	23	158EDS20S	12	10-10	8-7	7-6	9-6	7-6	6-7	8-7 f	6-10	6-0	7-0 f	6-0	5-3
				16	9-10	7-10	6-10	8-7 f	6-10	6-0	7-5 f	6-2	5-5	6-1 f	5-5	4-9
				24	8-7 f	6-10	6-0	7-0 f	6-0	5-3	6-1 f	5-5	4-7	5-0 f	4-9	4-2
2-1/2"	25 EQ	15	250EDS25	12	11-11 f	10-2	8-10	9-9 f	8-10	7-9	8-5 f	8-1	7-0	6-11 f	6-11 f	6-2
				16	10-4 f	9-3	8-1	8-5 f	8-1	7-0	7-4 f	7-4	6-5	6-0 f	6-0 f	5-7
				24	10-4 f	8-1	7-0	6-11 f	6-11 f	6-2	5-11 c	5-11 c	5-7	4-0 c	4-0 c	4-0 c
	20P* EQ	19	250EDS20P	12	13-10 f	11-1	9-8	11-4 f	9-8	8-5	9-9 f	8-9	7-8	8-0 f	7-8	6-8
				16	12-0 f	10-0	8-9	9-9 f	8-9	7-8	8-6 f	8-0	7-0	6-11 f	6-11 f	6-1
				24	9-9 f	8-9	7-8	8-0 f	7-8	6-8	6-11 f	6-11 f	6-1	5-8 f	5-8 f	5-4
	20S* EQ	23	250EDS20S	12	14-11	11-10	10-5	12-10 f	10-5	9-1	11-2 f	9-5	8-3	9-1 f	8-3	7-2
				16	13-7	10-10	9-5	11-2 f	9-5	8-3	9-8 f	8-7	7-6	7-11 f	7-6	6-7
				24	11-2 f	9-5	8-3	9-1 f	8-3	7-2	7-11 f	7-6	6-7	6-5 f	6-5 f	5-9
3-5/8"	25 EQ	15	358EDS25	12	14-8 f	13-5	11-9	12-0 f	11-9	10-3	10-5 f	10-5 f	9-4	7-4 c	7-4 c	7-4 c
				16	12-9 f	12-3	10-8	10-5 f	10-5 f	9-4	8-2 c	8-2 c	8-2 c	5-6 c	5-6 c	5-6 c
				24	10-5 f	10-5 f	9-4	7-4 c	7-4 c	7-4 c	5-6 c	5-6 c	5-6 c	3-8 c	3-8 c	3-8 c
	20P* EQ	19	358EDS20P	12	17-2 f	14-8	12-10	14-1 f	12-10	11-3	12-2 f	11-8	10-2	9-11 f	9-11 f	8-11
				16	14-11 f	13-4	11-8	12-2 f	11-8	10-2	10-6 f	10-6 f	9-3	8-5 c	8-5 c	8-1
				24	12-2 f	11-8	10-2	9-11 f	9-11 f	8-11	8-5 c	8-5 c	8-1	5-8 c	5-8 c	5-8 c
	20S* EQ	23	358EDS20S	12	19-10 f	15-10	13-10	16-2 f	13-10	12-1	14-0 f	12-6	10-11	11-5 f	10-11	9-7
				16	17-2 f	14-4	12-6	14-0 f	12-6	10-11	12-2 f	11-5	10-0	9-11 f	9-11 f	8-8
				24	14-0 f	12-6	10-11	11-5 f	10-11	9-7	9-11 f	9-11 f	8-8	8-1 f	8-1 f	7-7
4"	25 EQ	15	400EDS25	12	15-6 f	14-6	12-8	12-8 f	12-8 f	11-1	10-8 c	10-8 c	10-1	7-2 c	7-2 c	7-2 c
				16	13-5 f	13-2	11-6	10-8 c	10-8 c	10-1	8-0 c	8-0 c	8-0 c	5-4 c	5-4 c	5-4 c
				24	10-8 c	10-8 c	10-0	7-2 c	7-2 c	7-2 c	5-4 c	5-4 c	5-4 c	3-7 c	3-7 c	3-7 c
	20P* EQ	19	400EDS20P	12	18-2 f	15-10	13-10	14-10 f	13-10	12-1	12-10 f	12-7	11-0	10-6 f	10-6 f	9-7
				16	15-9 f	14-5	12-7	12-10 f	12-7	10-12	11-1 f	11-1 f	10-0	8-3 c	8-3 c	8-3 c
				24	12-10 f	12-7	11-0	10-6 f	10-6 f	9-7	8-3 c	8-3 c	8-3 c	5-6 c	5-6 c	5-6 c
	20S* EQ	23	400EDS20S	12	20-11 f	17-1	14-11	17-1 f	14-11	13-0	14-10 f	13-6	11-10	12-1 f	11-10	10-4
				16	18-1 f	15-6	13-7	14-10 f	13-6	11-10	12-10 f	12-4	10-9	10-6 f	10-6 f	9-5
				24	14-10 f	13-6	11-10	12-1 f	11-10	10-4	10-6 f	10-6 f	9-5	8-3 c	8-3 c	8-3
6"	25 EQ	15	600EDS25	12	18-10 c	18-10 c	17-2	12-7 c	12-7 c	12-7 c	9-5 c	9-5 c	9-5 c	6-4 c	6-4 c	6-4 c
				16	14-2 c	14-2 c	14-2 c	9-5 c	9-5 c	9-5 c	7-1 c	7-1 c	7-1 c	4-9 c	4-9 c	4-9 c
				24	9-5 c	9-5 c	9-5 c	6-4 c	6-4 c	6-4 c	4-9 c	4-9 c	4-9 c	3-2 c	3-2 c	3-2 c
	20P* EQ	19	600EDS20P	12	22-4 f	21-7	18-10	18-3 f	18-3 f	16-6	14-11 c	14-11 c	14-11 c	9-11 c	9-11 c	9-11 c
				16	19-4 f	19-4 f	17-2	14-11 c	14-11 c	14-11 c	11-2 c	11-2 c	11-2 c	7-6 c	7-6 c	7-6 c
				24	14-11 c	14-11 c	14-11 c	9-11 c	9-11 c	9-11 c	7-6 c	7-6 c	7-6 c	5-0 c	5-0 c	5-0 c
	20S* EQ	23	600EDS20S	12	25-10 f	23-4	20-4	21-1 f	20-4	17-9	18-4 f	18-3 f	16-2	14-11 f	14-11 f	14-1
				16	22-5 f	21-2	18-6	18-4 f	18-4 f	16-2	15-10 f	15-10 f	14-8	12-8 c	12-8 c	12-8 c
				24	18-4 f	18-4 f	16-2	14-11 f	14-11 f	14-1	12-7 c	12-7 c	12-7 c	8-5 c	8-5 c	8-5 c

NOTE:

Heights are based on the AISI North American Specification for the Design of Cold-Formed Steel Members, 2007 edition

Heights are limited by moment, deflection, shear and web crippling (assuming 1" end bearing)

Minimum material yield strength equals 40KSI for 15-, 19- and 23-mil studs

Bridging required at 48" O.C. or less

"f" denotes moment capacity controlled the limiting height

"c" denotes that web crippling controlled the limiting heights

No "f" or "c" adjacent to the height value indicates deflection controls the allowable wall height.

If a bearing stiffener is used a higher limiting height is possible

* The EDGE™ Performance 20 and The EDGE™ Super 20



FIRE RATING & SOUND ASSEMBLIES

INTERIOR NON-BEARING WALL RATINGS

Hour Rating	Wall Depth	Stud Depth	STC Rating	STC RSIC-V&1	Layers of Gypsum	Insulation R-Value	Sound Test	Stud Spacing	The EDGE™ (Mils)*
1	3 1/2"	2 1/2"	47		1 layer/1 layer of 1/2"	1 1/2" SAFB	SA-831001	24"	19
1	3 1/2"	2 1/2"	48 Est.		1 layer/1 layer of 1/2"	1 1/2" SAFB	Estimate	24"	15
1	4"	2 1/2"	50	RC-1	1 layer/1 layer of 1/2"	1 1/2" SAFB	RAL TL87-156	24"	19
1	4"	2 1/2"	50		1 layer/2 layer of 1/2"	1 1/2" SAFB	SA-800504	24"	19
1	4 7/8"	3 5/8"	49		1 layer/1 layer of 5/8"	R-13	WEAL TL10-588	16"	15
1	4 7/8"	3 5/8"	49		1 layer/1 layer of 5/8"	3" SAFB	SA-870717	24"	19
1	4 7/8"	3 5/8"	51		1 layer/1 layer of 5/8"	R-13	WEAL TL10-591	24"	15
1	5 3/8"	3 5/8"	54	RC-1	1 layer/1 layer of 5/8"	3" SAFB	RAL TL83-216	24"	23
1	5 3/8"	3 5/8"	54	RC-1	1 layer/1 layer of 5/8"	3" SAFB	RAL TL83-216	24"	19
1	5 3/8"	3 5/8"	56 Est.	RC-1	1 layer/1 layer of 5/8"	3" SAFB	Estimate	24"	15
1	5 1/2"	3 5/8"	53		1 layer/2 layer of 5/8"	R-13	WEAL TL10-587	16"	15
1	5 1/2"	3 5/8"	56		1 layer/2 layer of 5/8"	R-13	WEAL TL10-590	24"	15
1	6"	3 5/8"	53	RSIC-V®	1 layer/1 layer of 5/8"	R-19	WEAL TL07-636	24"	23
1	6"	3 5/8"	58	RC-1	1 layer/2 layer of 5/8"	3" SAFB	RAL TL83-215	24"	23
1	6 1/2"	3 5/8"	58	RSIC-1°	1 layer/1 layer of 5/8"	R-19	RAL TL87-156	24"	23
1	6 1/2"	3 5/8"	58	RSIC-1°	1 layer/1 layer of 5/8"	R-19	RAL TL05-013	24"	23
1	6 5/8"	3 5/8"	59	RSIC-V®	1 layer/2 layer of 5/8"	R-19	WEAL TL07-641	24"	23
1	7 1/8"	3 5/8"	61	RSIC-1°	1 layer/2 layer of 5/8"	R-19	RAL TL05-012	24"	23
2	3 5/8"	1 5/8"	51 Est.		2 layer/2 layer of 1/2"	1 1/2" SAFB	Estimate	24"	15
2	4 1/8"	1 5/8"	54 Est.		2 layer/2 layer of 5/8"	1 1/2" SAFB	Estimate	24"	15
2	5"	2 1/2"	51		2 layer/2 layer of 5/8"	2 1/2" SAFB	GA-WP-1548	24"	19
2	5"	2 1/2"	53 Est.		2 layer/2 layer of 5/8"	2 1/2" SAFB	Estimate	24"	15
2	6 1/8"	3 5/8"	57		2 layer/2 layer of 5/8"	R-13	WEAL TL10-586	16"	15
2	6 1/8"	3 5/8"	58		2 layer/2 layer of 5/8"	R-13	WEAL TL10-589	24"	15
2	7 1/4"	3 5/8"	64	RSIC-V®	2 layer/2 layer of 5/8"	R-19	WEAL TL07-642	24"	23
2	7 3/4"	3 5/8"	64	RSIC-1°	2 layer/2 layer of 5/8"	R-19	RAL TL05-011	24"	23
3	4 5/8"	1 5/8"	57 Est.		3 layer/3 layer of 1/2"	1 1/2" SAFB	Estimate	24"	15
3	4 5/8"	1 5/8"	59		3 layer/3 layer of 1/2"	1 1/2" SAFB	SA-830112	24"	19
3	5 3/8"	1 5/8"	59 Est.		3 layer/3 layer of 5/8"	1 1/2" SAFB	Estimate	24"	15
3	7 7/8"	3 5/8"	63	RC-1	3 layer/3 layer of 1/2"	3" SAFB	RAL TL87-152	24"	15
3	7 7/8"	3 5/8"	64 Est.	RC-1	3 layer/3 layer of 1/2"	3" SAFB	Estimate	24"	15
4	5 5/8"	1 5/8"	62		4 layer/4 layer of 1/2"	1 1/2" SAFB	SA-830113	24"	19
4	5 5/8"	1 5/8"	62 Est.		4 layer/4 layer of 1/2"	1 1/2" SAFB	Estimate	24"	15
4	6 5/8"	1 5/8"	63 Est.		4 layer/4 layer of 5/8"	1 1/2" SAFB	Estimate	24"	15

Superior STC results achieved by The EDGE™ 25 EQ stud:

1-hour
STC 51

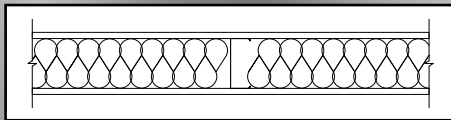

2-hour
STC 58

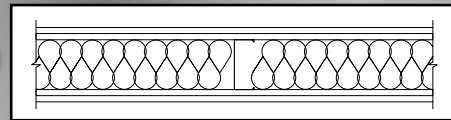

Tested results achieved using NO RC-1 channel, saving time and cost, while producing superior results.

Decibel rules of thumb for 25 gauge studs (15 mil) - adding resilient channels adds 2-3 STC points of 1 & 1 construction, 3-4 STC points for 2 & 1 construction, and about 5 STC points for 2 & 2 construction.

Notes:

- The EDGE™ 25 (15 mil)
- The EDGE™ Performance 20 (19 mil)
- The EDGE™ Super 20 (23 mil)

The EDGE™ meets UL Design Nos U419, V438 and V498.

Acoustical Performance - ASTM E90-09, E413-04 and E2235-04

Re-printed values with the consent of PAC-Intl. [RSIC-V® and RSIC-1°]

Estimates are based upon physical properties computer modeling and comparative analysis of actual test results.

* Design Thickness



ALLOWABLE SCREW DESIGN VALUES [lbs]

Member designation	#6 Screw Size (0.135" Dia.) – 5/8" Type X Gypsum					
	ASTM C645					
	Design Thickness (Mils)	Yield Fy (KSI)	Penetration	Shear	Pullover	Pull-out
The EDGE™25	15	40 KSI	Pass	-	-	-
The EDGE™ Performance 20	19	40 KSI	Pass	72	138	43
The EDGE™ Super 20	23	40 KSI	Pass	102	178	56
DW 30	31	33 KSI	Pass	129	129	55
DW 33	35	33 KSI	Pass	151	143	61

1 – Reference Documents: ASTM C645-09; AISI S100-07; AISI S905-08; ASTM A1003-10; ASTM A370-07

2 – The EDGE™ “Super20” was tested and approved by US Gypsum for use with their Fiberock & Durock panels

TOP TRACK DEFLECTION CLIP ITTC 450

Product Application:

The Top Track Clip secures interior drywall studs at head of wall which is top of wall to deck or building structural frame and allowing for vertical deflection of 3/4" up and down not designed for axial load.

Product Attributes:

1. Resist horizontal forces in both positive & negative direction.
2. Steel ASTM A653-CSB.
3. Ease of installation to top of wall or to primary structural frame is dependent upon base material (concrete or steel) and design configurations.
4. Sliding mechanism screw attachment to stud web.
5. Clip catalog available upon request

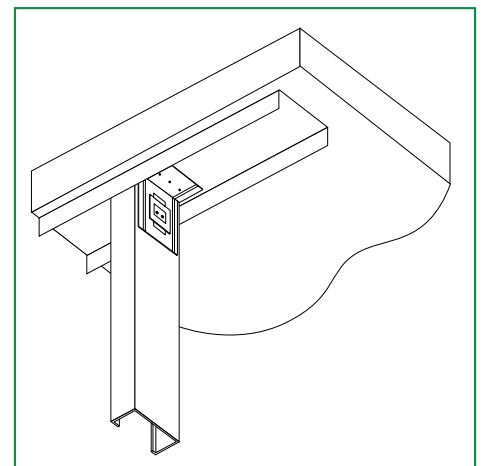

Allowable Vertical Design Load - Model No. ITTC 450 (for 3 5/8" to 6" studs)

Stud Design Thickness Inches	Stud Yield Strength KSI	Design Load Lbs.
0.015	40	-
0.019	40	180
0.023	40	220
0.033	33	300

Deep Leg Deflection Track and The EDGE™ Track (see notes below)

Model Number	Design Thickness (Mils)	Minimum Thickness (Inches)	Yield Strength	Coating
The EDGE™ Track	19	0.0179	40KSI	G40
	23	0.022	40KSI	G40
DW30	31	0.0312	33KSI	G40
18-Gauge	45	0.043	33KSI	G40
16-Gauge	56	0.054	50KSI	G40

Notes:

- Leg heights are available in 2", 2-1/2" and 3"
- Web available in 1-5/8", 2-1/2", 3-5/8", 4", 6" or 8"
- 1-5/8" deep leg track is offered with a maximum 2" leg
- AISI Wall Standard (S211), 2007 Edition
- Or equivalent per ASTM C645
- G60 and G90 are available by special order

Drywall Accessories

Zee Furring (ZF)

Steel Thickness: STD & 20 Gage
Standard Lengths: 8, 9 & 10 Ft.

Zee Furring facilitates the attachment of gypsum drywall to concrete or masonry walls. The depth of the furring varies to allow for the installation of insulation between the furring.

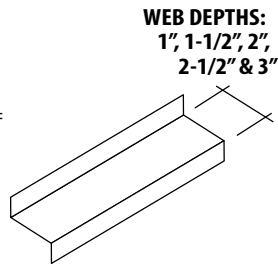

Resilient Channel (RC)

Steel Thickness: STD Gage
Standard Lengths: 10 & 12 Ft.

Resilient Channel is used for the attachment of gypsum wallboard to ceiling supports. The channel provides an airspace between the board and its support, thus enhancing the acoustical performance of the system.

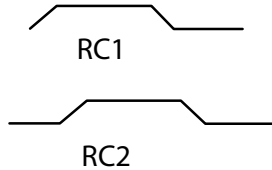

Cold Rolled Channel (CRC)

Steel Thickness: 16 Gage
Standard Lengths: 10 & 16 Ft.

Cold Rolled Channel has a number of uses ranging from cross furring and hangers in both plaster and gypsum wallboard ceilings to mechanical bridging for stud walls.

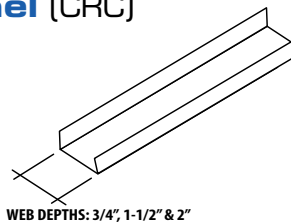

Utility Angle (UA)

Standard Steel Thickness:
 STD & 20 Gage
 [Angle formed of 18, 16, 14 and 12 gage steel available upon request]
Standard Lengths: 10 Ft.

Utility Angle is installed at corner conditions to provide continuous support for board products.

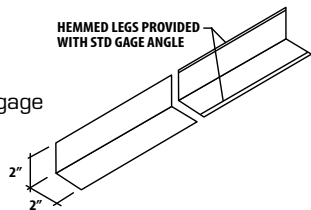

Clip Angles (CA)

Steel Thickness:
 20, 18, 16, 14 and 12 Gage

Clip Angles serve a variety of functions in the construction of a steel framing system. They may be used to make attachments between framing members or to transfer gravity and lateral loads from a stud to the primary frame.

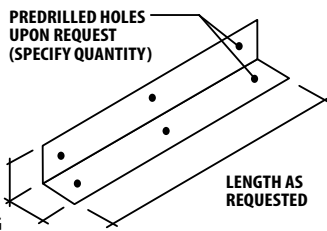

Furring Channel Clips

Furring Channel Clips are used to attach metal furring channel to 1-1/2" cold rolled channel in the construction of ceiling grids.

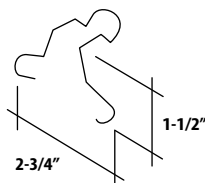

Flat Strap (FS)

Standard Thickness Offering: STD & 20 Gage
 [Flat strap formed from 18, 16, 14 & 12 gage steel available upon request]
Standard Width: 2", 4" & 6" [Custom widths available upon request]
Standard Length: 10 Ft.

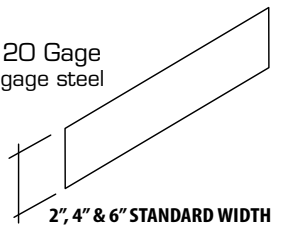

Flat Strap has a variety of uses that include wall bridging and backer plates to facilitate the installation of handrails and fixtures.

Big Bead® & Super Bead

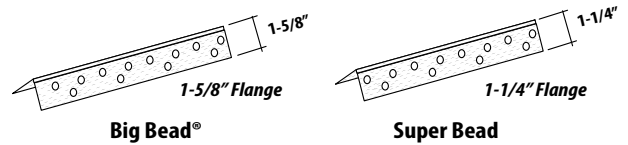

Big Bead® is a time save where double 5/8" gypsum board needs to be finished.

A positive attachment can be achieved with nails or screws.

High Quality Super Bead is used in conventional gypsum wallboard installations.

All of our corner beads provide a straight, smooth finished surface for outside corners of gypsum wallboard assemblies while it protects the corner from abuse and wear after installations.

Metal Trim Accessories

J, U & L Trim

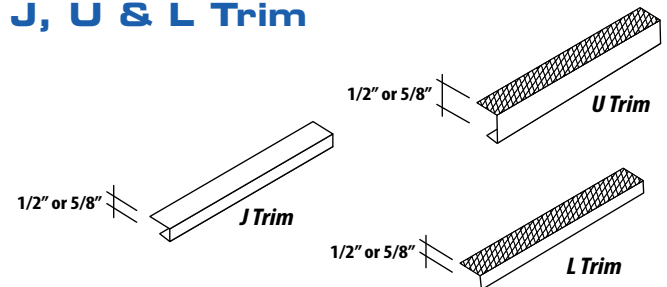

Metal trim is used to protect free edges of gypsum wallboards ranging in thickness from 1/2" to 5/8".

Standard Length: 8, 9 & 10 Ft.

J Trim	U Trim	L Trim
No. 401 - 1/2"	No. 201A - 1/2"	No. 201B - 1/2"
No. 402 - 5/8"	No. 202A - 5/8"	No. 202B - 5/8"

Grommets

Plastic, snap-in grommets, available in sizes to accommodate our standard web punchout widths, prevent contact between insulated wires or piping and the edge of the steel.

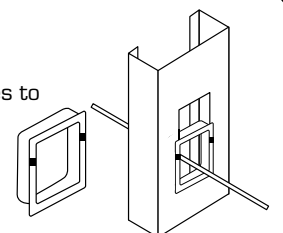



LEED Certification

Super Stud LEED® Information

Super Stud's framing products are manufactured from cold-formed steel supplied by a variety of integrated steel producers. Steel is the most recycled material on earth, and our framing products can contribute significantly to LEED® certification requirements for a project. The following information is taken directly from the American Iron & Steel Institute's [AISI] website and represents the method by which LEED® credits can be calculated. Our technical support staff is always available to assist with any aspect of this process. The following is reprinted by permission of the AISI. More complete information regarding steel's contribution to LEED® certification can be found at <http://www.recycle-steel.org/PDFs/leed/LEEDNov09.pdf>.

The U.S. Green Building Council Leadership in Energy & Environmental Design (LEED®) Green Building Rating System aims to improve occupant well-being, environmental performance and economic returns of buildings using established and innovative practices, standards, and technologies.

Materials & Resources Credit 4: Recycled Content intends to increase demand for building products that incorporate recycled content materials, therefore reducing impacts resulting from extraction and processing of new virgin materials. As discussed and demonstrated below, North American steel building products contribute positively toward points under Credits 4.1 and 4.2. The following is required by LEED-NC Versions 2.2 and 2009:

Credit 4.1 (1 point) Use materials with recycled content such that the sum of postconsumer recycled content plus one-half of the pre-consumer content constitutes at least 10% (based on cost) of the total value of the materials in the project.

Credit 4.2 (1 point) Use materials with recycled content such that the sum of post-consumer recycled content plus one-half of the pre-consumer content constitutes at least 20% of the total value of the materials in the project.

"The recycled content value of a material assembly shall be determined by weight. The recycled fraction of the assembly is then multiplied by the cost of assembly to determine the recycled content value." Since steel (the material) and steel (the building product) are the same, the value of the steel building product is directly multiplied by steel's recycled content, or:

Steel Recycled Content Value = (Value of Steel Product) (Post-Consumer % + 1/2 Pre-Consumer %)

The information contained within this brochure provides post-consumer and pre-consumer recycled content percentages for North American steel building products. These percentages and values of steel building products are easily entered into LEED Letter Template spreadsheet for calculation. To illustrate the application of these steel recycled content values to LEED, manual calculations are shown below for typical Basic Oxygen Furnace (BOF) and Electric Arc Furnace (EAF) steel building products with nominal \$10,000 purchases, using 2007 data. Steel building products include steel stud framing, structural steel framing (wide-flange beams, channels, angles, etc.), rebar, roofing, siding, decking, doors and sashes, windows, ductwork, pipe, fixtures, hardware (hinges, handles, braces, screws, nails), culverts, storm drains, and manhole covers.

BOF Steel Recycled Content Value for Typical Product:

Steel Stud Framing
Value = (\$10,000) (25.5% + 1/2 6.8%) = (\$10,000) (28.9%) = \$2,890
(Positive net contributor to 10% and 20% goals)

EAF Steel Recycled Content Value for Typical Product:

Wide-Flange Structural Steel Framing
Value = (\$10,000) (56.9% + 1/2 31.4%) = (\$10,000) (72.6%) = \$7,260
(Positive net contributor to 10% and 20% goals)

Super Stud
Building Products, Inc.
732-662-6200
www.buysuperstud.com

Steel Framing Alliance™
Steel. The Better Builder.

CFSEI

ASD
ASSOCIATION OF
STEEL DISTRIBUTORS

AWCI

American
Iron and Steel
Institute

U.S. GREEN BUILDING COUNCIL
USGBC

MASFA

ASTM
INTERNATIONAL
MEMBER

Super Stud Building Products

Super Stud Building Products, Inc. is an active member of the U.S. Green Building Council with LEED® Accredited Professionals on staff. Super Stud is committed to supplying quality products and continually looking for new ways to develop greener building products and sustainable business practices.



EQ Steel Framing System

is available from these licensed manufacturers:

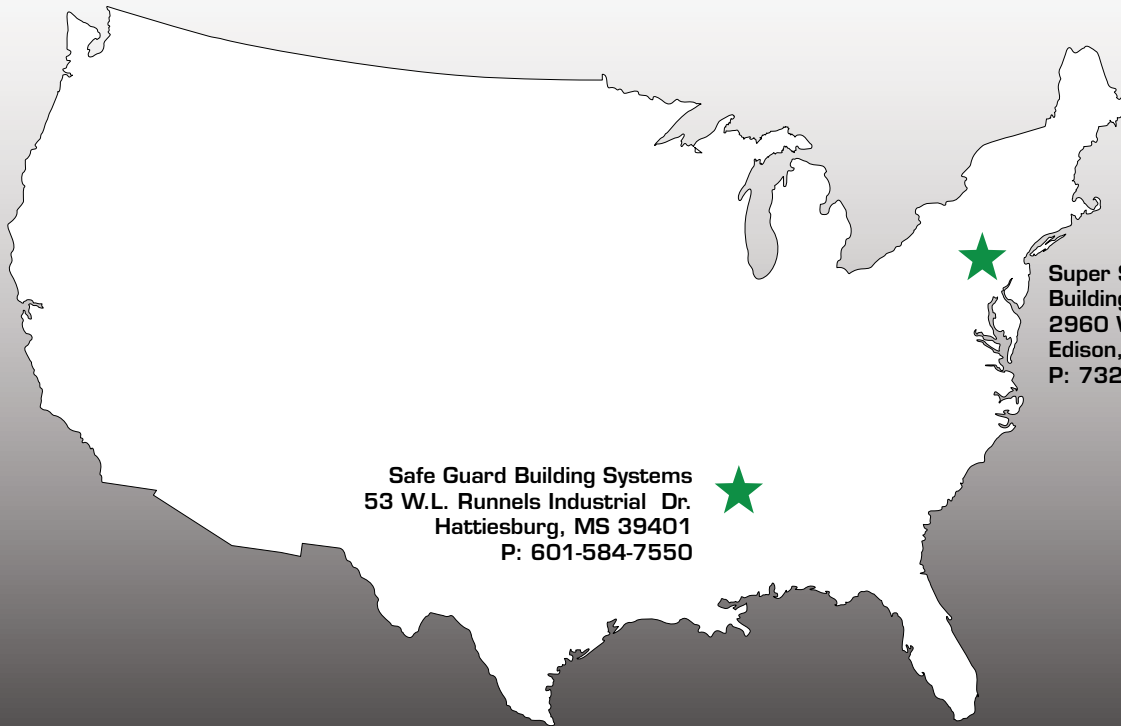

Safe Guard Building Systems
53 W.L. Runnels Industrial Dr.
Hattiesburg, MS 39401
P: 601-584-7550

Super Stud Building Products Inc.
2960 Woodbridge Ave.
Edison, NJ 08837
P: 732-662-6200

www.edgesteel framing.com

The Super Stud Building Products Group



Manufacturer of steel framing components, studs, joists and accessories.

www.buysuperstud.com



Licensed manufacturer of the FRO MAR Structural Panel System and the EDGE™ EQ Steel Framing System.

www.fromarsystems.com



Water Management, One Coat, Direct Applied and EIFS wall systems.

www.energexwallsystems.com



Distributors of magnesium oxide sheathing. DragonBoard is mold, mildew, water, fire and impact resistant. UL Certified.

www.dragonboard.com



Manufacturers of stock and custom hollow metal doors and frames. UL, FM and MEA certified.

www.galaxymetalproducts.com

2960 Woodbridge Ave. - Edison, New Jersey 08837

P: 800-477-7883 | F: 732-548-6036