

## Slotted Deflection Track

### Specification Section:

- 05.40.00 (Cold-Formed Metal Framing)
- 09.22.16 (Cold-Formed Metal Framing)

**Yield Strength:** 33 kips per square inch (KSI) minimum for 43 mil and thinner

### Material - Nonstructural:

- DW 25 GA = 18 mil / 0.0179" G40 Coated
- DW 20 GA = 30 mil / 0.0312" G40 Coated

### Material - Structural:

- 20 GA = 33 mil / 0.0329" G60 Coated (G90 available)
- 18 GA = 43 mil / 0.0428" G60 Coated (G90 available)
- 16 GA = 54 mil / 0.0538" 50 KSI G60 Coated (G90 available)
- 14 GA = 68 mil / 0.0677" 50 KSI G60 Coated (G90 available)
- 12 GA = 97 mil / 0.0966" 50 KSI G60 Coated (G90 available)
- 10 GA = 118 mil / 0.1180" 50 KSI G60 Coated (G90 available)

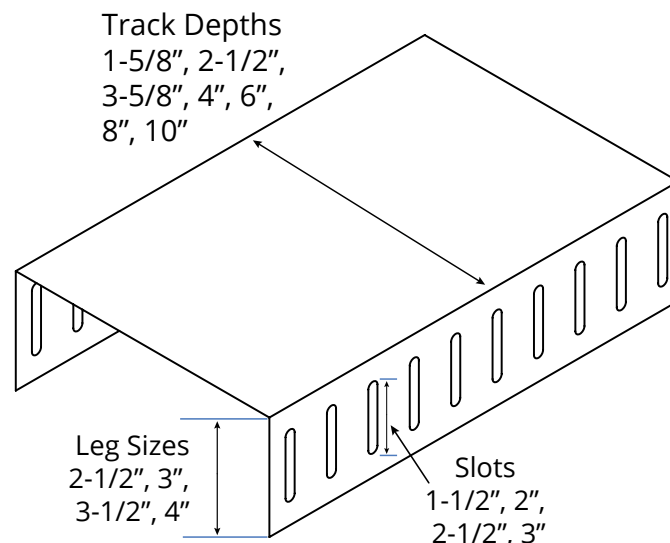

UL Designs: HW-D-0632 and HW-D-0633

Geometric Properties	
Web Depth	1-5/8", 2-1/2", 3-5/8", 4", 6", 8", 10"
Leg Length	2-1/2", 3", 3-1/2"
Slot Size	1-1/2", 2", 2-1/2"

Slotted Deflection Track is a CFS top track manufactured to prevent cracking of finishes applied to interior partition framing resulting from deflection of structure above.

This is achieved by fastening studs to top track through provided slots, allowing fastener vertical movement of up to 1 1/2". Fasten each stud flange through slots using #8 or #10 screws by minimum 9/16" long, wafer head, self tapping or self-drilling. There shall be no attachment through the slotted track that will impair movement.

Testing and approval is in accordance with ANSI/UL 2079, "Tests for Fire Resistance of Building Joint Systems."

### CODES AND STANDARDS:

Super Stud/EB Metal US products comply with the applicable provisions of the following:

- International Building Code (IBC): 2006–2024
- AISI S100-16 (2020) w/S2-20
- Sheet Steel: ASTM A1003/A1003M; ASTM A653/A653M
- Galvanized Coating: ASTM A653/A653M

### Structural Members:

- ASTM C955; AISI S240
- Installed per ASTM C1007

### Additional Standards:

- AISI S201; AISI S202
- 3rd Party Certification

For LEED Letter requests please submit through:  
[www.buysuperstud.com](http://www.buysuperstud.com) or [www.ebmetal.us](http://www.ebmetal.us)

NEW HAMPSHIRE FACILITY  
 12 TALLWOOD DRIVE  
 BOW, NH 03304  
 P: 603-216-1573

MISSISSIPPI FACILITY  
 53 W L RUNNELS IND DR  
 HATTIESBURG, MS 39401  
 P: 601-584-7550

NEW JERSEY FACILITY  
 2960 WOODBRIDGE AVE  
 EDISON, NJ 08837  
 P: 732-662-6200