

## 800SJ200-97

Product Description: 8" Super Joist 12GA (2" Flange, 97mil)

Coating: G60 (standard), G90 (special order)

Specification Section: 05.40.00 (Cold-Formed Metal Framing)



GEOMETRIC PROPERTIES			
Web Depth	8 in.	Yield Strength, Fy	50 ksi
Flange Width	2 in.	Design Thickness	0.1017 in.
Lip Length	0.625 in.	Min. Steel Thickness	0.0966 in.

GROSS PROPERTIES		
Area (in <sup>2</sup> )	Total cross-sectional steel area	1.2706
Weight (lb/ft)	Linear weight per foot	4.3200
I <sub>x</sub> (in <sup>4</sup> )	Moment of inertia about the x-axis	11.2069
S <sub>x</sub> (in <sup>3</sup> )	Section modulus about the x-axis	2.8017
R <sub>x</sub> (in)	Radius of gyration about the x-axis	2.9698
I <sub>y</sub> (in <sup>4</sup> )	Moment of inertia about the y-axis	0.5779
R <sub>y</sub> (in)	Radius of gyration about the y-axis	0.6744

EFFECTIVE PROPERTIES		
Max (in-k)	Maximum allowable bending moment	73.6396
I <sub>xe</sub> (in <sup>4</sup> )	Effective moment of inertia (x-axis)	10.4155
S <sub>xe</sub> (in <sup>3</sup> )	Effective section modulus (x-axis)	2.5562
V <sub>a</sub> (k)	Maximum allowable shear force about the y-axis	2570.8

TORSIONAL PROPERTIES		
J x 1000 (in <sup>4</sup> )	St. Venant torsional constant	4.381
C <sub>w</sub> (in <sup>6</sup> )	Warping constant	7.094
X <sub>o</sub> (in)	Distance from shear center to centroid	1.203
R <sub>o</sub> (in)	Polar radius of gyration	3.274
Beta	Torsional Flexural Constant	0.865

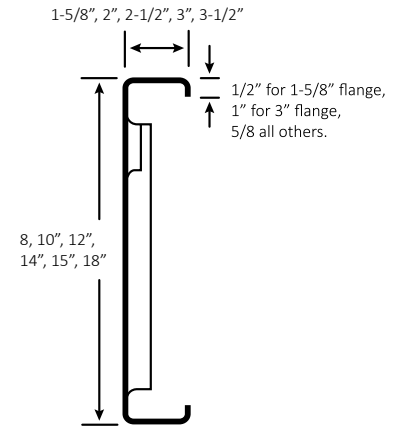

TYPICAL JOIST MEMBER SIZING				
A	B	C	D	E
Section Web Depth (in)	Large Hole Diameter (in)	Large Hole Spacing (in o.c.)	Small Hole Diameter (in)	Minimum Distance from End to Center of First Large Hole (in)
8	4.25	9	1	22

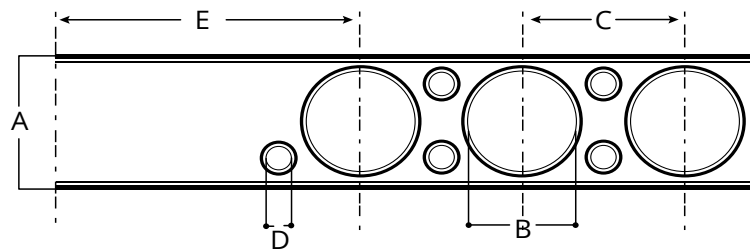

### CODES AND STANDARDS:

Super Stud/EB Metal US products comply with the applicable provisions of the following:

- International Building Code (IBC): 2006–2024
- AISI S100-16 (2020) w/S2-20
- Sheet Steel: ASTM A1003/A1003M; ASTM A653/A653M
- Galvanized Coating: ASTM A653/A653M

### Structural Members:

- ASTM C955; AISI S240
- Installed per ASTM C1007

### Additional Standards:

- AISI S201; AISI S202

### 3rd Party Certification

For LEED Letter requests please submit through:  
[www.buysuperstud.com](http://www.buysuperstud.com) or [www.ebmetal.us](http://www.ebmetal.us)